

## double girder trolley, 4 rope falls (reeving 4/1)

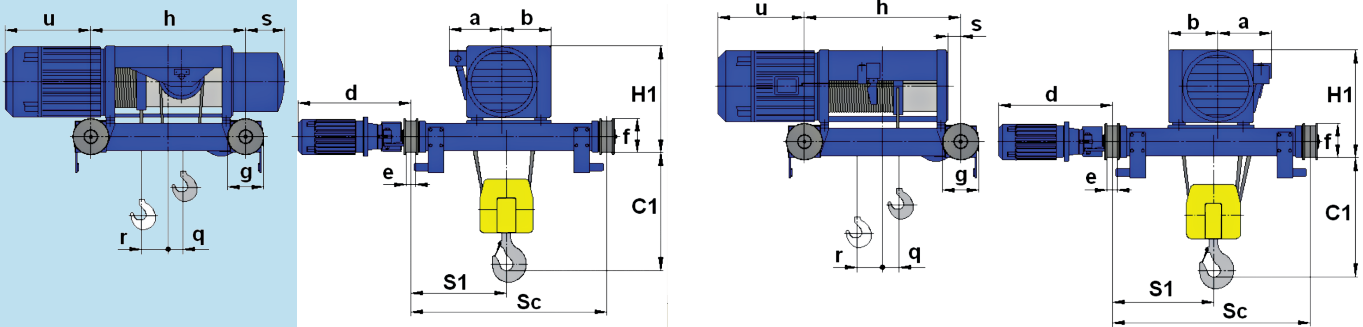

Hoist type	Capacity, kg	Fixed dimensions, mm													
		C1	Sc	S1	H1	a	b	d*	e	e1	e2	f	g	g1	sp
1	2	3	4	5	6	7	8	9	10	11	12	13	14	15	16
MT305	2000	505	1000	484	476	229	240	465	50	75	40	173	160	185	30
MT308	3200	550	1000	484	476	229	240	465	50	75	40	173	160	185	30
MT312	5000	615	1000	478	476	229	240	500	50	75	40	173	160	185	30
MT316	6300	635	1000	478	476	229	240	500	50	75	40	173	160	185	30
MT525	10000	670	1000	477	543	279	265	575	50	75	40	173	160	185	30
M740	16000	826	1200	640	735	410	358	610	60	90	50	220	200	240	40

d\* - for travel speed 20/6 m/min.

Hoist type	Hook travel, m	Weight, kg		Variable dimensions, mm					
		Motors		h	q	r	s	Motors	
		NA	VA					u	u
1	2	3	4	5	6	7	8	9	10
MT3051	7	374	378	720	132	-25	99,5	257	276
MT3052	10	394	398	900	222	-69	99,5	257	276
MT3053	13	422	426	1085	314	-115	99,5	257	276
MT3081	7	378	416	720	132	-25	99,5	276	383
MT3082	10	398	436	900	222	-69	99,5	276	383
MT3083	13	426	464	1085	314	-115	99,5	276	383
MT3121	7	512	519	770	137	-19	146	383	383
MT3122	10	544	550	975	239,5	-71,5	146	383	383
MT3123	13	576	583	1175	339,5	-122	146	383	383
MT3161	7	524	549	770	137	-19	146	383	507
MT3162	10	556	581	975	239,5	-71,5	146	383	507
MT3163	13	588	613	1175	339,5	-122	146	383	507
MT5251	7	670	-	790	133	-15	166	512	-
MT5252	10	710	-	995	236	-67	166	512	-
MT5253	13	750	-	1195	336	-117	166	512	-
M7401	7	1343	1418	833	64	45	91,5	594	392
M7402	9	1390	1465	993	117	36	91,5	594	392
M7403	13	1555	1630	1208	224	-18	91,5	594	392

suspended version / solution possible

## double girder trolley, 4 rope falls (reeving 4/1)

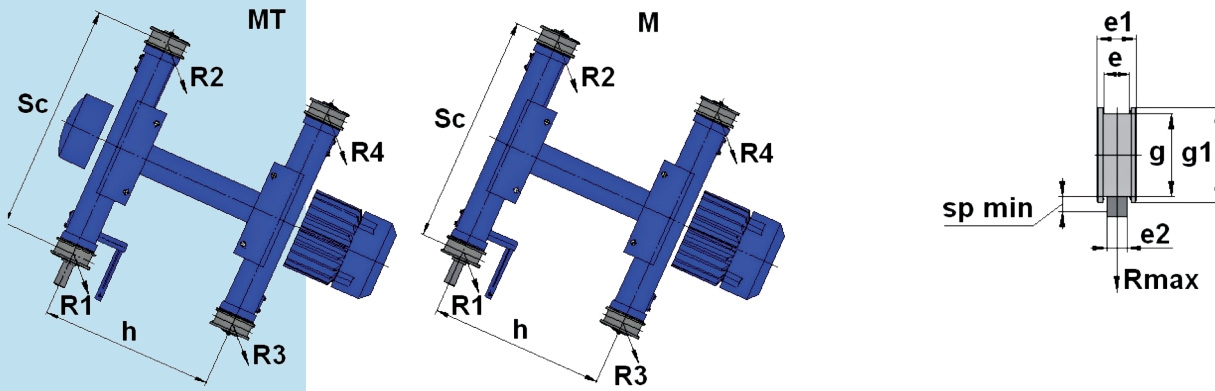

Hoist type	Capacity, kg	Hook travel, m											
		7				10				13			
		R1	R2	R3	R4	R1	R2	R3	R4	R1	R2	R3	R4
1	2	3	4	5	6	7	8	9	10	11	12	13	14
MT305	2000	814	740	420	400	881	803	363	347	934	854	324	310
MT308	3200	1237	1137	618	586	1345	1239	520	494	1424	1314	455	433
MT312	5000	1901	1721	980	910	2086	1892	811	755	2209	2005	704	658
MT316	6300	2361	2143	1205	1115	2593	2357	988	918	2748	2498	850	791
MT525	10000	3664	3316	1921	1769	4034	3656	1571	1449	4275	3875	1350	1250
M740	16000	4633	5193	3533	3984	4948	5552	3242	3648	5492	6169	2779	3115

The reactions are for upper end position of the hook and speed NA.