

Crane Components

Main Products Outline

**Arguably
the most reliable
rope hoist**



Podem is one of the world's leading suppliers of complete range of crane components to all sized independent crane manufacturers around the world

Timeline



April 1, 1961

The official establishment of Podem.

The Bulgarian based state owned production company was created to supply the crane industries in European countries with electrical wire rope hoists.



1981

Podem became the biggest hoists manufacturer worldwide. Production capacity reached 100,000 wire rope hoists per year. Podem created distributions in more than 70 countries around the world represented by its commercial structures Balkancarpodem and other Podem brand names.

By using Podem's products you will get:

- Quality products in full compliance with the International standards
- Highest possible reliability level offered in the industry as a result of very big experience in product design, modern production organization and strict quality control
- Competitive prices for standard and non-standard hoists and crane kits
- Up-to-day technical characteristics of the products thanks to our close connection with our distributors and knowledge of the markets
- Different lifting solutions matching your individual needs thanks to experienced team of mechanical and electrical engineers and flexible organization
- Full range of spare parts not only for the existing models but also for all products produced in the past
- 24 hour sales and technical support
- Marketing support



2001

The former state owned company was fully privatized. The new company Podemcrane AD – the successor of Podem, started operation and continued to promote the Podem brand along with the new one Podemcrane.



2016

The company is the biggest crane component manufacturer in CEE and has remained at the forefront of technological developments in the industry. 30 000 sq.m high-tech production factory with modern equipment located in EU. Sales of hundred standard products in more than 55 markets.

Thanks to our 55 years experience

in the development and production of hoisting equipment
Podem can deliver high quality reliable products
at most competitive price

Main Products

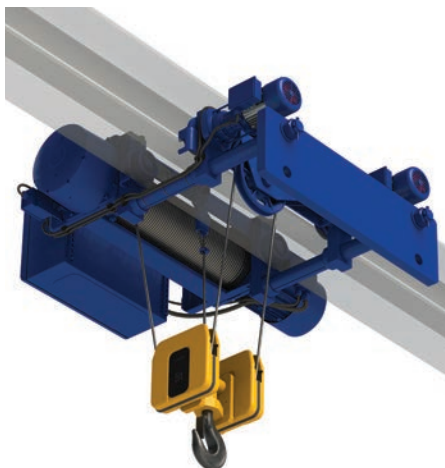

Wire Rope Hoists and Trolleys

The range provides solutions for new industrial cranes or replacement applications.

Standard technical features:

- Monorail or double girder hoist
- Standard capacity: from 1 to 50 t
- FEM group: 1 Am – 3 m

Advantages:

- Highest possible reliability levels offered in the industry
- Operational safety
- Long life
- Excellent price/performance ratio
- Easy maintenance
- Low service costs



End Carriages

Podemcrane manufactures end carriages for single or double girder cranes. We can support individual design for different crane manufacturers.

Standard technical features:

- Type: Overhead, Gantry or Underslung cranes
- Standard capacity: from 1 to 50 t
- Span: up to 32 m
- Wheel diameter: up to 500 mm

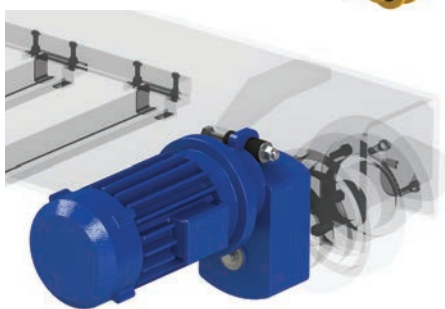

Motor-reducers (Crane Drives)

Developed for driving of travel mechanisms for material handling equipment (trolleys, cranes, etc.).

Standard technical features:

- From 0,37 to 3 kW
- Wheel diameter from 125 to 500 mm



Chain Hoists

Comprehensive range with compact design, superior quality and high standard of safety.

Standard technical features:

- Capacity: from 125 to 5 000 kg

Special Solutions

Podemcrane offers also advanced engineering for custom made solutions in various industries:

- Hoist and end-carriages up to 100 t
- Various power supply
- Ability to operate in various environmental conditions and climatic zones:
 - Cold: up to -40°C
 - Tropical or Hot climate: up to $+50^{\circ}\text{C}$
- Curved monorail trolley
- Radio controlled and tandem
- Frequency controlled speed
- Beside the standard type the trolley can be designed for 2 hoists with same or different capacities
- Components for ladle, galvanized, chemical or food industry

Crane Kits for Single or Double Girder Cranes

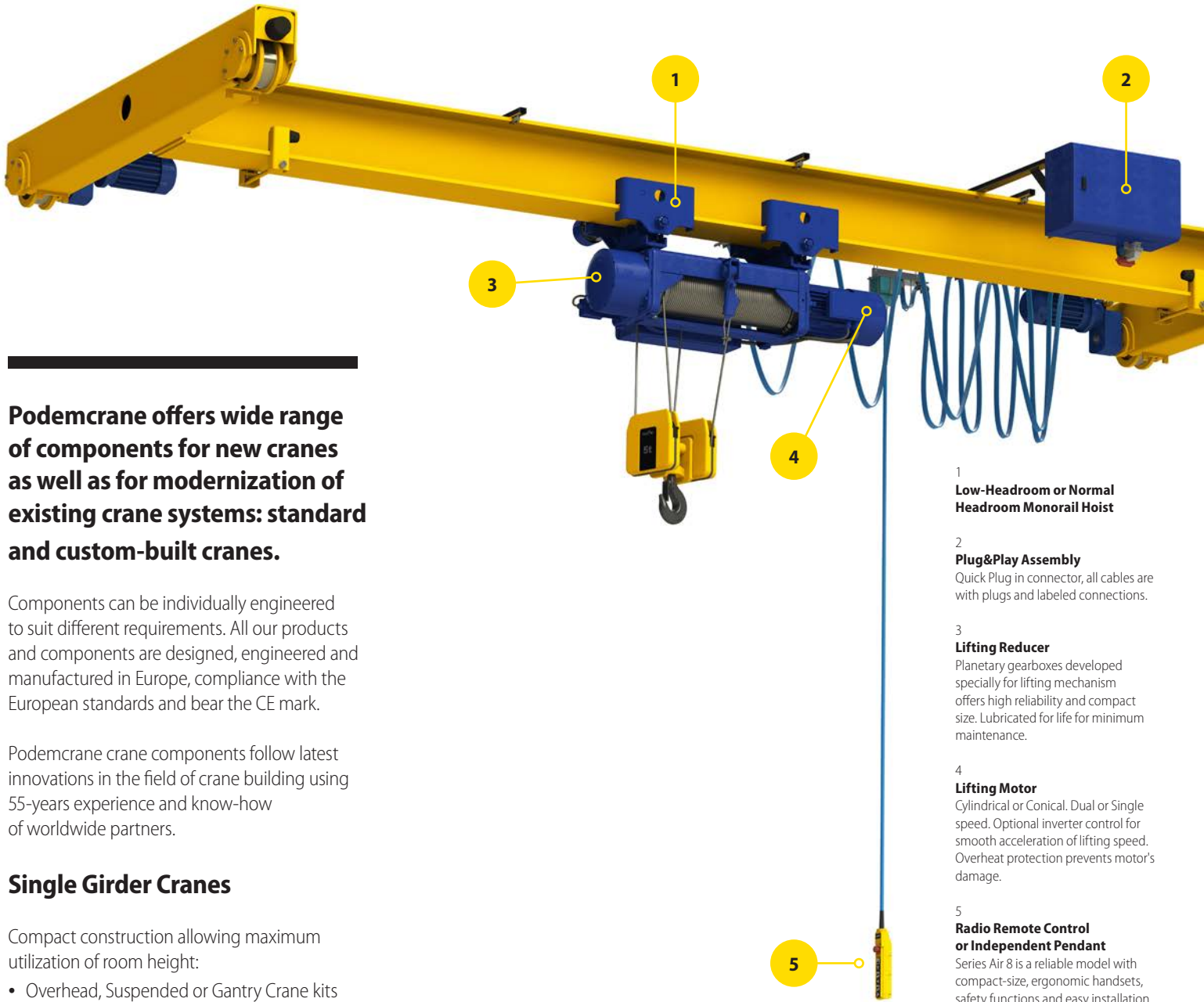

Podemcrane offers wide range of components for new cranes as well as for modernization of existing crane systems: standard and custom-built cranes.

Components can be individually engineered to suit different requirements. All our products and components are designed, engineered and manufactured in Europe, compliance with the European standards and bear the CE mark.

Podemcrane crane components follow latest innovations in the field of crane building using 55-years experience and know-how of worldwide partners.

Single Girder Cranes

Compact construction allowing maximum utilization of room height:

- Overhead, Suspended or Gantry Crane kits
- Standard capacity: 1 – 16 t
- Standard span: 5 – 32 m

1 **Low-Headroom or Normal Headroom Monorail Hoist**

2 **Plug&Play Assembly**
Quick Plug in connector, all cables are with plugs and labeled connections.

3 **Lifting Reducer**
Planetary gearboxes developed specially for lifting mechanism offers high reliability and compact size. Lubricated for life for minimum maintenance.

4 **Lifting Motor**
Cylindrical or Conical. Dual or Single speed. Optional inverter control for smooth acceleration of lifting speed. Overheat protection prevents motor's damage.

5 **Radio Remote Control or Independent Pendant**
Series Air 8 is a reliable model with compact-size, ergonomic handsets, safety functions and easy installation. Back-up pendant (connected to the control panel) is very reliable, with ergonomic compact design and easy for handling and operation.

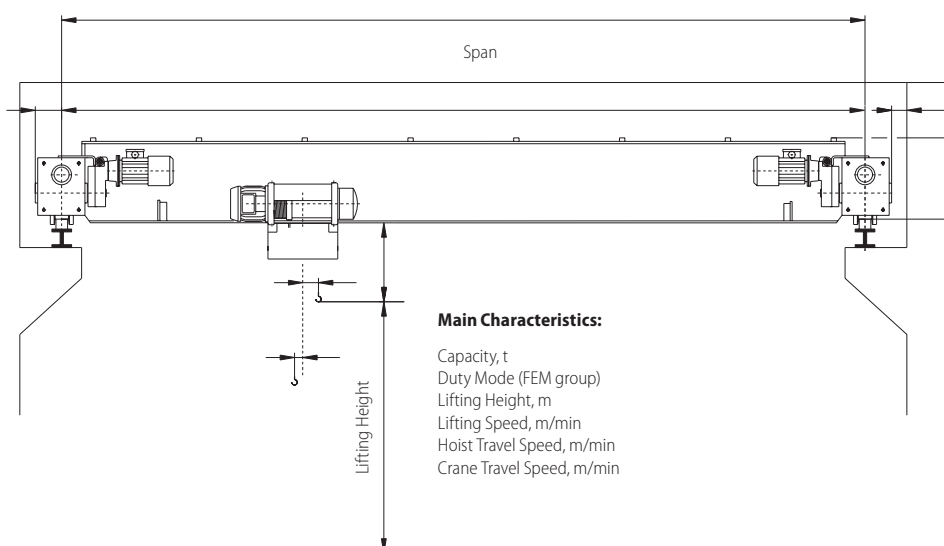

Standard Podem Crane Kits:

- Hoist unit including trolley mechanism and electrical control panel
- End-carriages with plates, buffers and travel drives
- Crane Control Panel
- Control (RRC or pendant)
- Festoon system - preassembled
- Drawings for main girder fabrication
- Accessories (lights, towing arms, panel holders, etc)

Optional Devices for Podem Crane Kit:

- Bus-bar Conductor Systems
- Inverter control for lifting
- Anti-collision devices
- Load LED display
- Horn
- Energy drag chain
- Crane spot lights, etc.



6
Travel Limit Switches
Travel limit switches for cross and long travel - pre- and limit switching in both directions of travel.

7
Festoon System
European made cable carrying line (in galvanized steel or in stainless steel) is a handy, efficient and safe system for electrical distribution.

8
Maintenance Platform
Safety and Easy for assembling.

9
Double Rail Crab
With one or two lifting mechanisms.

10
Rope Guide
Made of tough fiber-plastic or metal guaranties reliable operation even in critical environments. Rollers mounted on anti-friction bearings allows smooth rope lead and prolongs the life of the rope.

11
Contactor Control
The high quality contactor control for reliable performance in any conditions.

12
Over-load Limiter
All hoists are endowed with overload limiter are with 2 reaction thresholds: Warning and Stop.

Optional: monitoring system or load display. Advantages for maintenance: the operating data of the hoist can be read out with a laptop.

13
End-carriages
End-carriages for EOT cranes with wheel diameters from 125 mm to 500 mm. Beam Connection Plates and buffer-stops are supplied as standard. End-carriages for suspension cranes – spans up to 20 m, up to 12,5 t.

14
Crane travel Drives
Low-maintenance drives with inverter as standard.

The main Podem crane kits features are reliability, safety and attractive cost effectiveness intended to crane manufacturers or crane service providers.

Advantages for the customer:

- Reduced transport costs
- Reduced manufacturing costs of the entire crane by using the preset components
- Reduced on-side installation time by Plug&Play Podem crane kit because of less working steps and prepared cables and connections

Double Girder Cranes

Applied when greater capacity and higher operation required. In equal conditions double girder cranes offer greater lifting heights:

- Overhead or Gantry Crane kits
- Standard capacity: 2000 – 50000 kg
- Standard span: 5 – 32 m

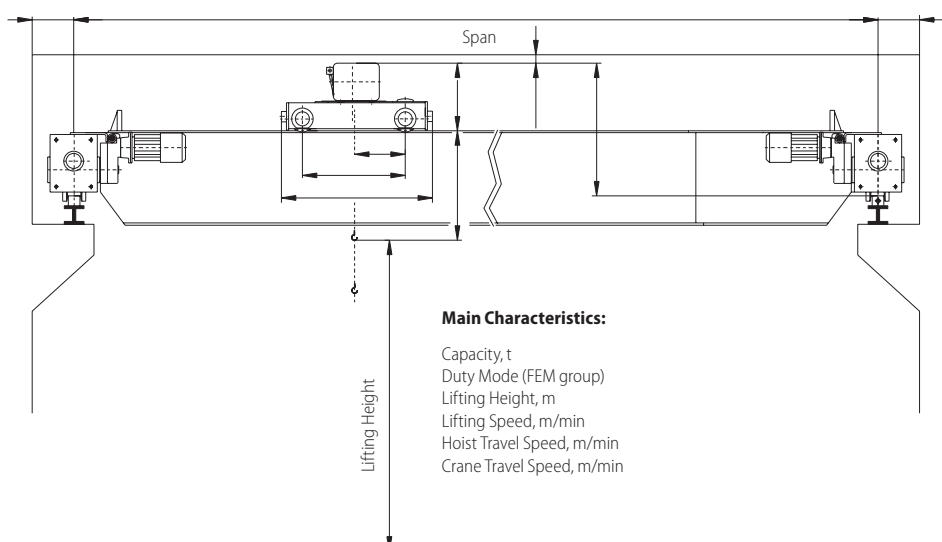



Enclosed Conductor Systems

- Compact, reliable and safe electrical power supply
- Continuous copper conductor system: 35 – 320 A
- Jointed copper conductor system: 50 – 400 A
- Safety features complying with European Low Voltage directive 2006/95/EC
- IP23/IP44 protection class possible
- Modular concept and easy mounting
- High grade 99,9% pure copper conductors
- Low wear of brushes and trolleys
- Options for special applications (galvanizing, steel mill, cement industry)



Gantry Crane Kits

- Know-how and advanced engineering experience
- Wide range of single or double girder crane
- Standard capacity: 5 - 50t
- Span: from 10 to 35m
- Indoor or outdoor application
- Control by RRC or cabin

Crane kit doesn't include, fixed and flexible legs. Podem could provide fabrication drawings for metal structure.



Jib Cranes

- Column- and wall-mounted slewing jib cranes
- Largest slewing jib crane programme
- Capacity from 125 to 20 000 kg
- Outreach max. from 2 to 12m
- Indoor or outdoor
- Slewing manual or electrical
- Largest program for standard and special accessories
- Short response time for offers, orders, spare parts and any kind of questions

Project Reference



Standard Products Table

Capacity (kg)	Groups		Hoist type	Rope falls	Lifting speed (m/min)*		Lifting height (m)			
	FEM	ISO			V1	V2	H0	H1	H2	H3
1000	2 m	M5	MT305	2/1	8/2,6	12/4	10	14	20	26
1600	2 m	M5	MT308	2/1	8/2,6	12/4	10	14	20	26
2000	3 m	M6	MT310	2/1	8/2,6	12/4	10	14	20	26
	2 m	M5	MT305	4/1	4/1,3	6/2	–	7	10	13
2500	3 m	M6	MT306	4/1	4/1,3	6/2	–	7	10	13
	2 m	M5	MT312	2/1	8/2,6	12/4	10	14	20	26
	2 m	M5	MTL312	2/1	–	12/4	32	40	48	56
3200	2 m	M5	MT316	2/1	8/2,6	12/4	10	14	20	26
	2 m	M5	MT308	4/1	4/1,3	6/2	–	7	10	13
	2 m	M5	MTL316	2/1	–	12/4	32	40	48	56
4000	3 m	M6	MT310	4/1	4/1,3	6/2	–	7	10	13
	3 m	M6	MT520	2/1	8/2,6	12/4	10	14	20	26
5000	3 m	M6	MT313	4/1	4/1,3	6/2	–	7	10	13
	2 m	M5	MT312	4/1	4/1,3	6/2	–	7	10	13
	2 m	M5	MT525	2/1	8/2,6	12/4	10	14	20	26
	2 m	M5	MTL525	2/1	–	12/4	32	40	48	56
6300	1 Am	M4	MT532	2/1	8/2,6	12/4	10	14	20	26
	2 m	M5	MT316	4/1	4/1,3	6/2	–	7	10	13
8000	3 m	M6	MT520	4/1	4/1,3	6/2	–	7	10	13
	2 m	M5	M740	2/1	8/2,6	12/1,8	13	18	25	32
10000	2 m	M5	MT525	4/1	4/1,3	6/2	–	7	10	13
	2 m	M5	M750	2/1	5,5/1,3	8/1,5	13	18	25	–
	2 m	M5	M950	2/1	5/1,2	10/1,5	–	20	32	–
12500	1 Am	M4	MT532	4/1	4/1,3	6/2	–	7	10	13
	3 m	M6	M732	4/1	4/1,3	6/0,9	6,5	9	12,5	16
16000	2 m	M5	M740	4/1	4/1,3	6/0,9	6,5	9	12,5	16
	3 m	M6	M940	4/1	2,5/0,6	5/0,75	–	10	16	24
20000	2 m	M5	M750	4/1	2,8/0,7	4/1,1,3	6,5	9	12,5	16
	2 m	M5	M950	4/1	2,5/0,6	5/0,75	–	10	16	24
25000	1 Am	M4	M963	4/1	2,5/0,6	5/1,6	–	10	16	24
32000	1 Am	M4	M980	4/1	2,5/0,6	4/0,75	–	10	16	24
40000	2 m	M5	M1100	4/1	2/0,6	4-0,4	10	12	15	22
50000	1 Am	M4	M1125	4/1	2/0,6	4-0,4	10	12	15	22

For more information and technical catalogue please contact our local distributor



Podemcrane AD

1 General Nikolov St.
5300 Gabrovo, Bulgaria
t +359 66 801 375
f +359 66 801 390
sales@podem.bg
podem.bg

